

The Phoenix Mars Lander Robotic Arm

Robert Bonitz, Lori Shiraishi, Matthew Robinson, Joseph Carsten, Richard Volpe, Ashitey Trebi-Ollennu

Jet Propulsion Laboratory
California Institute of Technology
4800 Oak Grove Drive
Pasadena, CA 91109-8099

Robert.G.Bonitz,Lori.R.Shiraishi,Matthew.L.Robinson,Joseph.Carsten,volpe,ashitey@jpl.nasa.gov

Raymond E. Arvidson
Department of Earth and Planetary Sciences
Washington University in Saint Louis
Saint Louis, MO 63130
arvidson@rsmail.wustl.edu

P. C. Chu, J. J. Wilson, K. R. Davis
Honeybee Robotics Spacecraft Mechanisms Corporation
460 W. 34th Street
New York, NY 10001
chu,wilson,davis@honeybeerobotics.com

Abstract—The Phoenix Mars Lander Robotic Arm (RA) has operated for 149 sols since the Lander touched down on the north polar region of Mars on May 25, 2008. During its mission it has dug numerous trenches in the Martian regolith, acquired samples of Martian dry and icy soil, and delivered them to the Thermal Evolved Gas Analyzer (TEGA) and the Microscopy, Electrochemistry, and Conductivity Analyzer (MECA). The RA inserted the Thermal and Electrical Conductivity Probe (TECP) into the Martian regolith and positioned it at various heights above the surface for relative humidity measurements. The RA was used to point the Robotic Arm Camera to take images of the surface, trenches, samples within the scoop, and other objects of scientific interest within its workspace. Data from the RA sensors during trenching, scraping, and trench cave-in experiments have been used to infer mechanical properties of the Martian soil. This paper describes the design and operations of the RA as a critical component of the Phoenix Mars Lander necessary to achieve the scientific goals of the mission.¹²

TABLE OF CONTENTS

1. INTRODUCTION	1
2. SYSTEM DESCRIPTION	2
3. SURFACE OPERATIONS	5
4. CONCLUSION	10
ACKNOWLEDGEMENTS	10
REFERENCES	10
BIOGRAPHY	11

1. INTRODUCTION

The Phoenix Mars Lander (Figure 1) touched down on the north-polar region of Mars on May 25, 2008 and began its

primary 90-sol (sol = 1 Martian day) mission of scientific exploration in the vicinity of the landing site [10]. Favorable conditions permitted extending major operations through 149 sols after which limited energy permitted only restricted operations consisting primarily of collecting weather data. The RA was an essential system for achieving the scientific goals of the Phoenix mission by providing support to the other science instruments as well as conducting specific soil mechanics experiments [11]. One of the primary mission goals was to analyze soil samples in the TEGA [1], and MECA [2][3]. The RA supported these goals by acquiring both surface and sub-surface dry and icy soil samples from the area in the vicinity of the Lander and dumping the samples into the TEGA and MECA inlet ports. Subsurface samples were acquired at varying depths from within trenches excavated by the RA. Very strong icy soil was encountered at shallow depths (~2 to 7 cm).

In addition to delivering samples, the RA positioned the RAC to take images of the surface, trench floor and end walls, rocks, and dumped soil piles. During soil sample acquisition, the scoop was positioned for the RAC to take close up images of the soil samples in the scoop prior to delivery to the TEGA or MECA. There is a specially-designed depression in the scoop blade to contain small samples that allowed for very close imaging by the RAC at high spatial resolution. The arm positioned the RAC for imaging of the TEGA and MECA entry ports for pre- and post-delivery assessment of the delivery process. The RAC was also used for stereo imaging of the surface to generate digital elevation maps (DEMs) for use by the RA operations team in building RA command sequences.

The RA inserted the TECP [9] probes into the soil to characterize thermal and electrical conductivity. The RA also positioned the TECP to measure atmospheric relative humidity from 0.15 m to 1.8 m above the surface.

¹ 978-1-4244-2622-5/09/\$25.00 ©2009 IEEE.

² IEEEAC paper #1695, Version 5, Updated December 15, 2008

The RA performed its required activities successfully enabling the science instruments to analyze samples *in-situ* from which to infer physical properties, geomorphology, chemistry, and mineralogy of the north-polar region.

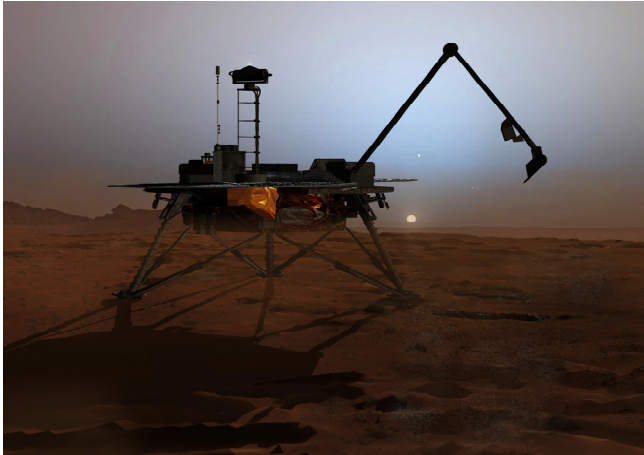

Figure 1 — Phoenix Mars Lander depicted as winter approaches

2. SYSTEM DESCRIPTION

Mechanical Overview

The RA (Figure 2) is a 4-degree-of-freedom manipulator with a back-hoe design that provides motion about shoulder yaw (azimuth), shoulder elevation, elbow, and wrist pitch [4]. The arm was designed to withstand the harsh environment at the landing site: diurnal temperature excursions from -90° to -20°C , CO_2 atmosphere, pressure as low as 5 Torr. The arm links are made of aluminum with titanium end fittings. The end effector consists of the forearm-mounted RAC, and the scoop and TECP mounted on the wrist (Figure 3).

The scoop is divided into a front chamber that collects materials excavated by the front blade and a rear chamber that houses the rasp and collection area for samples produced by rasp. The two chambers are separated by a labyrinth through which material is transferred from rear to front by rotating the entire scoop about the RA wrist axis. See Figure 5.

The front chamber is used to collect regolith during digging and sample acquisition. This chamber includes a funnel feature which channels acquired material into a slot, improving the accuracy of sample delivery (Figure 4). The scoop and funnel are made of aluminum with a clear anodize for abrasion and wear resistance. This coating on the interior surfaces also reduces glare when viewing acquired samples with the RAC. A tungsten carbide secondary blade on the bottom side of the scoop provides a means of penetrating harder materials and is used primarily for scraping on indurated material.

The joint actuators consist of brushed DC motors with multi-stage speed reduction consisting of planetary gears and a harmonic drive (except the wrist, which has a bevel gear at the output of the planetary gears). Braking is achieved by actively shorting the motor leads to slow the motor until magnetic detents capture the rotor. The detents provide sufficient holding torque to assure no slippage while power is off. Position sensing is accomplished via quadrature encoders at the motor shaft and potentiometers at the joint output. The encoder counters are initialized based on potentiometer data or by running each joint up against a known mechanical hardstop located at the end of each joint's travel. The encoder counts are stored in flash memory at the end of each day for use during initialization the following day. Each joint is equipped with a heater and temperature sensor to assure that the motor operation is conducted at or above minimum operating temperature.

The RA workspace is located on the north side of the Lander and is depicted in Figure 6.

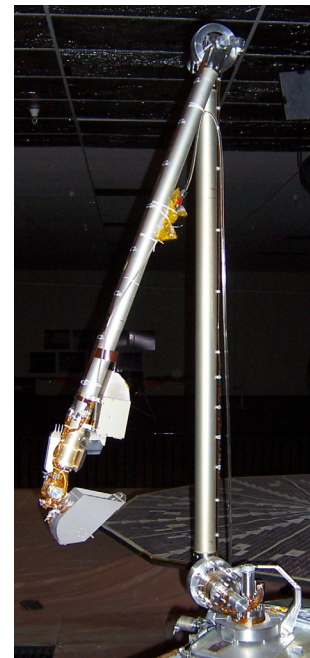

Figure 2 — Engineering model of the 2.4m-long Phoenix RA in the Payload Interoperability Testbed at the University of Arizona

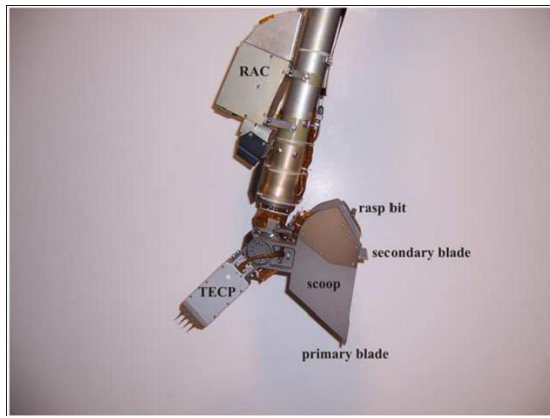

Figure 3 – RA end effector tool suite: scoop with primary and secondary blades for scraping and a rasp for acquiring icy soils; RAC for imaging soil and rock targets, instrument ports, and the scoop interior; and TECP for measuring temperature and electrical conductivity



Figure 4 – Scoop interior showing the channel used to guide the material sample when delivering to the TEGA and the MECA

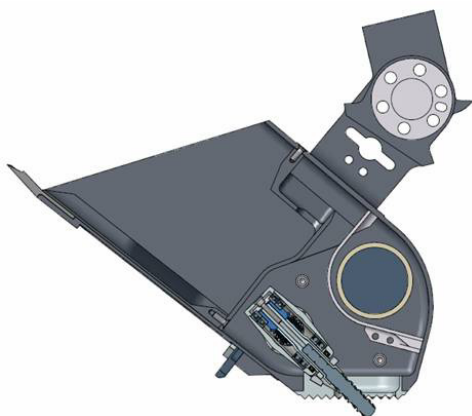

Figure 5 – Cut-away view of the scoop showing the rasp, rear and front scoop chambers, and primary and secondary blades

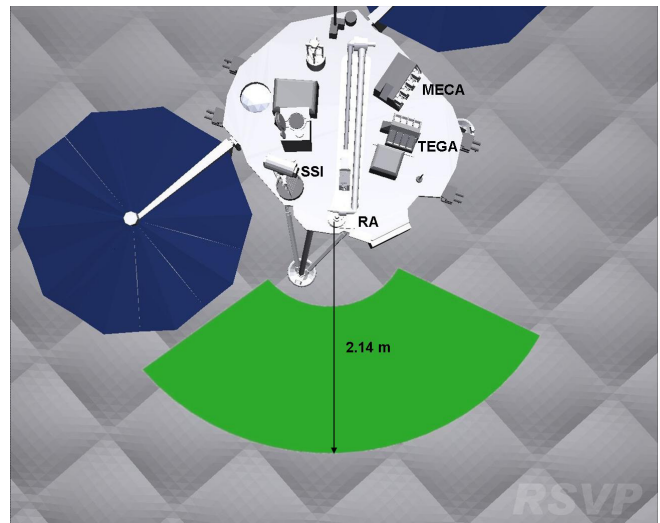

Figure 6 – Area reachable by the scoop is shown in green and represents the digging workspace on the Martian surface

Rasp

The rasp is high-speed cutting tool mounted on the back of the scoop and is the primary tool for acquiring icy soil samples. The bit is made of tungsten carbide and is driven by a brushed DC motor. Torque is transferred from the motor shaft to the rasp cutting bit through a set of spur gears and a pair of miter gears, yielding an overall speed reduction of 1.25:1 from the motor to the bit. The motor is powered by a current-limited on-off circuit, which provides current up to the limit to the motor during operation. The device includes resistive strip heaters that warm the mechanism to allowable operational temperatures. A temperature sensor on the motor provides temperature feedback. All components used to power the rasp cutting bit are thermally isolated from the main scoop body by an insulating material. This thermal isolation helps ensure that the icy-soil samples are kept cold, thus, minimizing loss due to sublimation.

Icy soil acquisition is accomplished by first preloading the scoop against the surface so that the spring-loaded rasp cutting bit retracts into the scoop. A knurled contact plate grips into the icy soil to prevent motion of the scoop during rasp operations. The rasp cutting bit is then energized, resulting in rapid penetration of the surface, causing a plume of cuttings to ballistically enter the rear chamber of the scoop. The rasp cutting bit is mounted within a pivoting housing, allowing the bit to protrude out of the scoop during sample acquisition as well as to retract fully into the scoop during preloading. The pivot housing is spring loaded using a torsion spring. The torsion spring acts to force the cutting bit into the material, providing the necessary load on the bit for penetration into icy soil.

The rasp is also used to provide vibration to help move samples from the rear chamber of the scoop to the front

chamber and down the front funnel to the instrument inlet ports. The vibration is provided by a cam feature attached to the rasp cutting bit that engages a low-friction surface, which is grounded with respect to the scoop. As the rasp bit rotates at high speed, the cam feature causes the pivot housing to oscillate such that the spring-loaded housing impacts its lower hard stop once per revolution, causing high-frequency vibration.

Bio-barrier

To prevent contamination of the Martian sub-surface with Earth organisms per NASA planetary protection policy, the RA meets Category IV-B bio-burden requirement [5]. In order to meet this requirement, the RA was sterilized prior to final integration onto the Lander and encased in a bio-barrier [13] (Figure 7). The bio-barrier maintained sterilization during the journey to Mars and was deployed shortly after landing on the Martian surface.

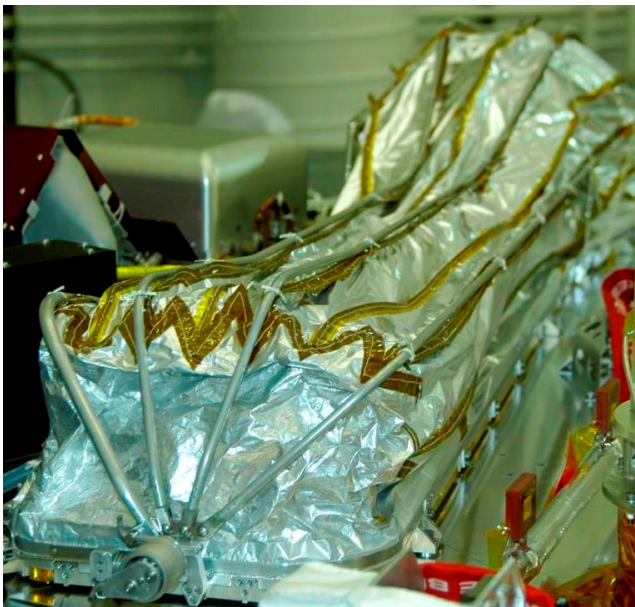

Figure 7 — RA shown encased in the bio-barrier that maintained sterility to prevent contamination of the Martian sub-surface with Earth organisms. The bio-barrier was held in place by a series of latches that were released shortly after landing by a pyro-activated pin puller. Torsion springs at each end then rotated the ribs (right to left in the figure) to open the bag.

Control Electronics

The RA Electronics (RAE) consists of two printed-circuit boards located in the lower Payload Electronics Box (PEB) and provides power conditioning; motor voltage control and drivers; heater drivers; joint encoder counting; and analog-to-digital conversion of potentiometer voltages, temperature sensor voltages, motor currents, and heater current. A board mounted externally on the PEB limits the current to the rasp to prevent overheating. The RAE provides the interface to the Lander Command and Data Handling

(C&DH) computer over a serial link. Firmware running on the RAE microprocessor provides for low-level motor command execution to move the joints to the specified positions, heater and rasp command execution, analog-to-digital calibration, and sensor monitoring.

Algorithms and Software

The RA flight software resides on the Lander Command and Data Handling computer and provides the following functions:

- Initialization (load parameter table, collision object data base, and state files; request power on);
- Expansion of high-level task commands (e.g., dig);
- Generation of arm movement trajectories;
- Validation of collision-free motion paths;
- Control of arm motion, joint heaters, and rasp;
- Setting parameters (e.g., motor current limits) in the RAE;
- Reading sensor data and monitoring the arm status;
- Fault detection and recovery;
- Sending arm sensor data to telemetry.

The RA has a full suite of arm motion commands that provide for coordinated joint motion as well as Cartesian motion of the end effector [8]. Joint moves are specified as either absolute moves or relative moves to the current position. Cartesian moves are specified as absolute or relative moves with respect to the payload coordinate frame located at the base of the RA. The operator specifies Cartesian motion in the local frame of the currently-selected tool (scoop, scraping blade, TECP, rasp load plate, or RAC). The four degrees of freedom for Cartesian position are specified as the three translation coordinates plus the angle that the currently selected tool approach vector makes with the plane of the Lander deck (except for the RAC whose orientation cannot be controlled separately). Each motion command is broken up into a series of via points that are sent sequentially to the RAE for execution by the firmware.

The arm is also commanded to perform more complicated tasks such as digging a trench or acquiring a sample using the scoop by a single command. The software expands the high-level command into the appropriate set of motion commands which are executed sequentially. This approach saves uplink bandwidth and eases the burden on the operator in developing complicated command sequences. The software also tracks time and energy resources used during command execution and will gracefully terminate operations when allocations are exceeded. This feature was most useful when digging a trench due to the uncertainty of the soil properties that affect the execution of the dig trench command.

In addition to providing for control of the free-space arm motions, the software is also capable of executing guarded moves where the arm moves towards its commanded position until contact is made. This is accomplished by monitoring motor currents and computed joint torques versus preset thresholds. Guarded moves are employed when inserting the TECP into the ground, preloading the rasp load plate on a hard icy surface, acquiring samples, and digging trenches. Thus, RA operation is robust with respect to surface location uncertainty.

To aid in safety and increase autonomy, the RA software is capable of detecting and recovering from faults and anomalous events. Faults and events are defined as follows:

- Fault - inability to complete a command due to failure of hardware (sensor, actuator, electronics, etc.);
- Event - inability to complete a command due to anything other than a fault (e.g., arm motion impeded by a rock in the digging path).

If a fault or event is detected, the fault or event type is reported in telemetry. Depending on the fault or event detected, the RA software either attempts to recover from the fault or event or place the arm in a safe configuration. When the RA encounters conditions that impeded its motion during digging (a rock in the soil, encountering the icy soil table, etc.), the software engages a built-in accommodation algorithm, similar to the one reported in [7] to compensate for this condition by adjusting the scoop trajectory and, if necessary, dumping the scoop contents and re-executing the digging motion.

The primary operations tool for commanding the Phoenix RA is the Rover Sequencing and Visualization Program (RSVP) [6] used on Pathfinder and the Mars Exploration Rover projects and adapted for Phoenix. RSVP provides target designation from panorama image data, generates command subsequences via programmed macros, simulates arm motion, checks for collisions, estimates command durations, and outputs a complete command sequence file for uplink to the Lander.

3. SURFACE OPERATIONS

Overview

This section includes a brief description of the process used to operate the arm and the results of some example activities. RA operations depended heavily on imaging data from the Surface Stereo Imager (SSI) and the RAC. The SSI and RAC were used to generate digital elevation models (DEMs) of the RA workspace for use in defining targets for RA activities (digging, scraping, sample acquisition, rock pushing, and TECP insertion into the surface). Each RA activity that involved interaction with the terrain was preceded by imaging and DEM generation

which was then imported into the RSVP. An example is shown in Figure 8.

RA command sequences were then generated using RSVP's built-in sequence editor. The RA operator visually verified that the commanded RA motion in each sequence was as planned using RSVP's motion simulator prior to uplink to the Lander.

Image data were used to verify the results of each terrain-interacting RA activity including assessing trench profiles, rasp placement and ejecta, post-scraping surface topography, TECP insertion impressions, quantity of sample acquired, and the sample delivery process. RA sensor data was imported into RSVP and arm motions played back to verify completion of arm activities. The playbacks were very useful in determining where indurated layers (e.g., ice table) were encountered during trenching since they visually showed where the arm went into its surface accommodating mode and when hard material impeded arm motion (Figure 9).

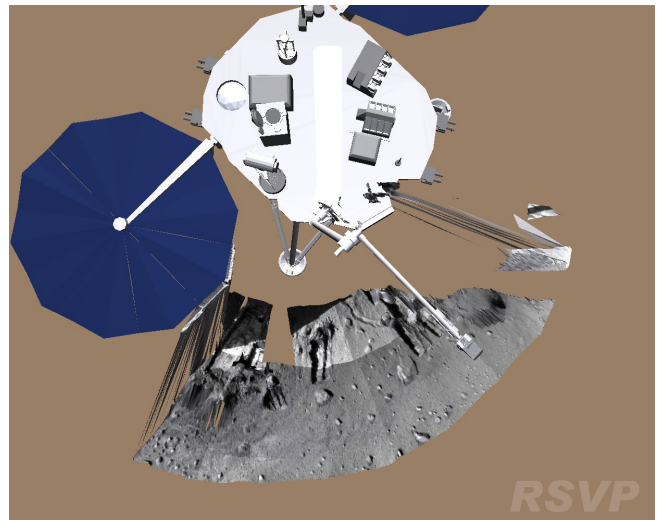

Figure 8 – RSVP with DEM of the terrain from SSI images acquired from sols 0 through 84

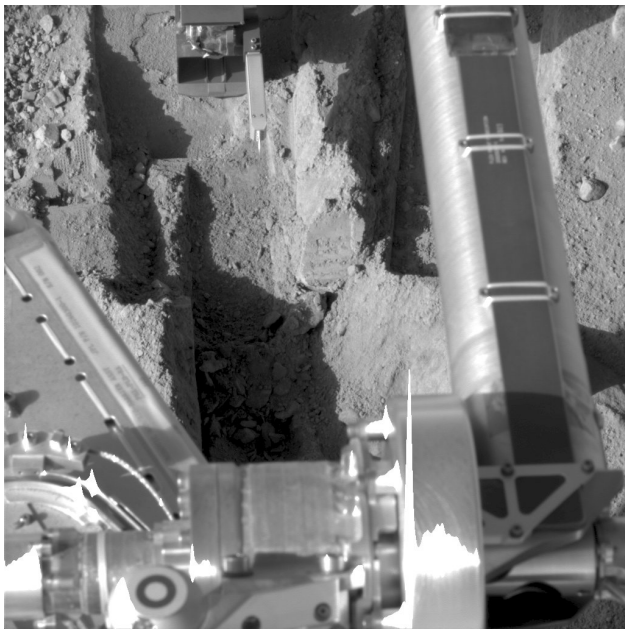

Figure 9 — View from the SSI of the right-side of the tip of the RA scoop encountering a hard spot during digging a trench on sol 140

Digging

The RA executed 53 dig sequences during the Phoenix mission trenching in 11 different areas. Indurated layers were encountered during trenching between approximately 2 and 10 cm below the surface in almost all areas of the workspace as evidenced by increased joint torques, engagement of the surface accommodation algorithm, and motion impeded events. The indurated layers were sloped down towards the Lander; i.e., deeper closer to the Lander. The reason that hard layers dip toward the lander is that the digging was on the edge of polygonal-patterned ground [12] and toward the southern sides of these gentle mounds. Hard layers of icy soil were observed on polygons (e.g., Snow White) and perhaps crusty soil in troughs (e.g., Stone Soup). The deepest trench, Stone Soup, was approximately 15 cm deep at its proximal end to the Lander. Since indurated material frequently impeded motion of the arm during digging and scraping activities, autonomous recovery from these events was enabled in the flight software and command sequences. This permitted subsequent arm operations to continue without ground operator intervention saving valuable sols that would otherwise have been used for recovery operations.

An example of trenching is the Snow White trench dug on the east side of the RA workspace done from sols 22 through 126 shown in Figure 10. The trench is approximately 25 cm wide by 75 cm long with a maximum depth of 5 cm. An ice table was encountered approximately 3 cm below the surface during the second dig activity. Subsequent digging and scraping operations involved extending and grooming the trench in preparation for sample acquisition activities. A total of seven digging and

twelve scraping activities were executed as part of excavating the Snow White trench.

A summary of all trenches is shown in Figure 11.

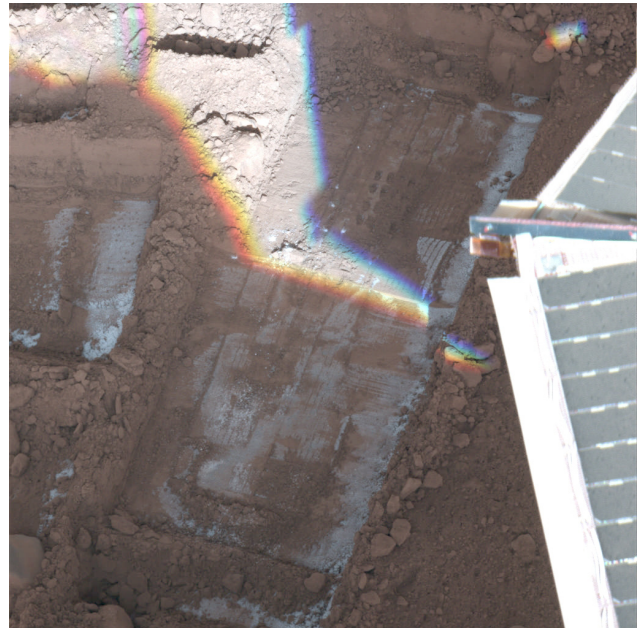

Figure 10 — The SSI took this false-color image of the Snow White trench on sol 141. A smaller trench named Burn Alive is shown on the left side of the image. The light blue regions are indicative of frost accumulation.

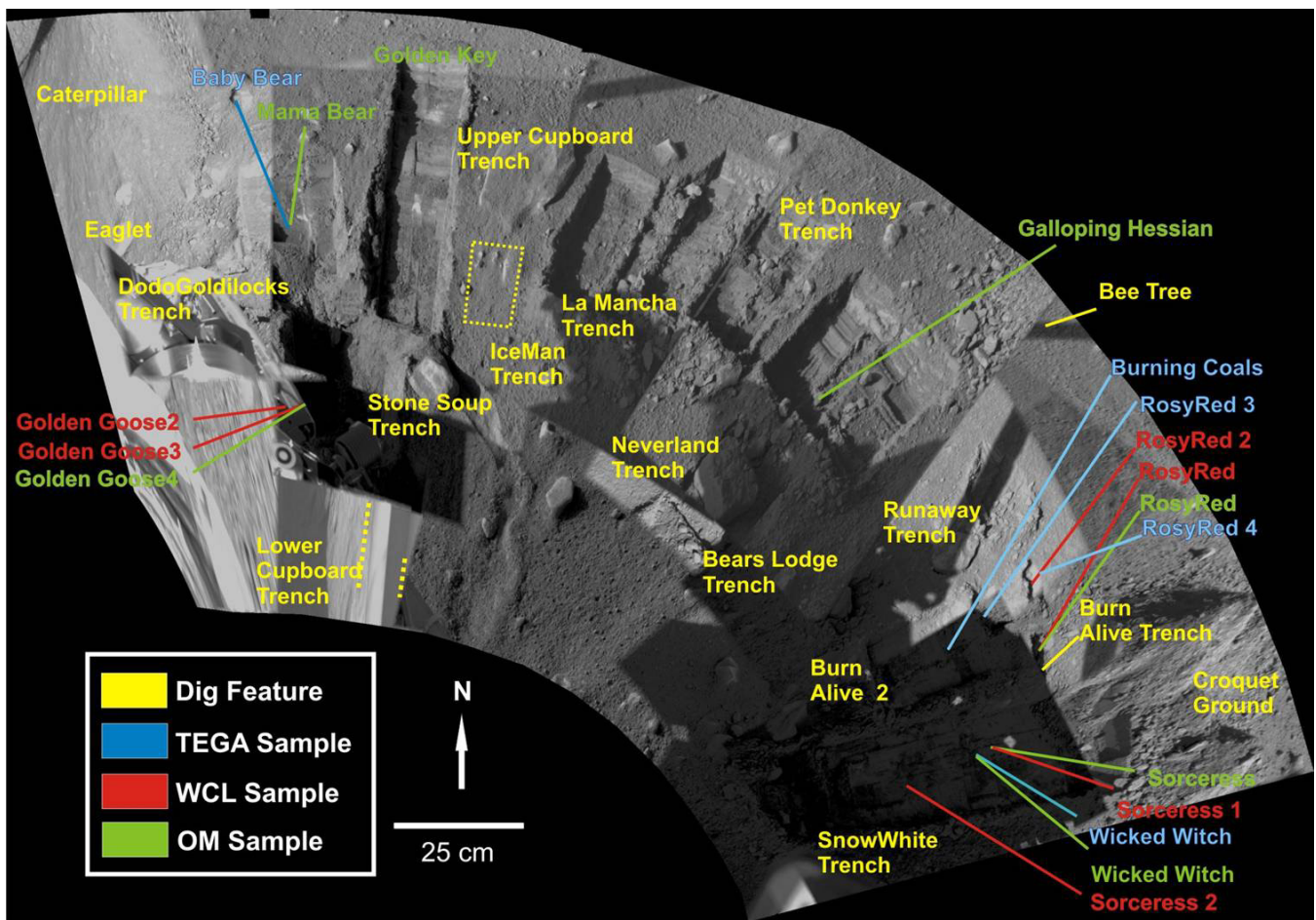

Figure 11 - An SSI mosaic showing all RA trenching and sample acquisition sites

Regolith Sample Acquisition

A total of seventeen samples were acquired and successfully delivered to the instruments for *in-situ* analysis – five to TEGA, four to MECA Wet Chemistry Lab (WCL), and eight to the MECA Optical Microscope (OM). The samples were primarily acquired from the regolith (e.g., soil, broken rock fragments) with one sample of indurated (icy-soil) material delivered to TEGA.

To improve the chances of successful sample delivery, the scoop was positioned above the selected instrument inlet and a RAC image acquired and compared to a similar image taken in the Payload Interoperability Testbed. The images were then overlaid for comparison and corrections to the positioning made as necessary. An example is shown in Figure 12. Following each sample delivery the RAC was used to document the results (Figure 13). The RAC was also used to document the contents of scoop prior to delivery (Figure 14).



Figure 12 – This image consists of two overlaid RAC images of the scoop posed over MECA WCL 0 ready for delivery on sol 29 - one from Mars and the other from the PIT



Figure 13 — The RAC took this image shortly after the RA delivered a sample from Rosy Red to MECA WCL 0 (lower left cell) on sol 66 verifying successful delivery

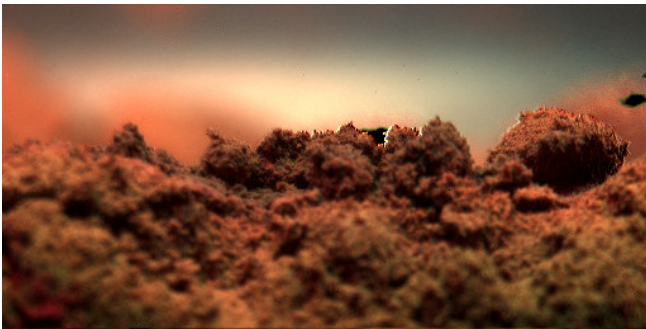

Figure 14 — The RAC took this image of the sample in the scoop divot acquired for TEGA from Rosy Red on sol 72 with scoop tip positioned directly in front of the RAC for high-resolution imaging

Icy-Soil Sample Acquisition

One of the more difficult operations that the RA performed was the acquisition and delivery of an icy-soil sample from the Snow White trench. Prior to sample acquisition, several scraping activities were performed in the trench to flatten the surface in order to achieve optimal placement of the rasp load plate on the surface. The surface was also lightly scraped immediately prior to rasping to remove any loose material on the surface. The acquisition consisted of sixteen rasps in a 4x4 grid, transferring the acquired sample from the back chamber of the scoop to the front chamber, and then very carefully scooping up rasp ejecta from the surface. This process yielded approximately 2.5 cc of material. The acquisitions were done early in the morning so that the scoop was as cold as possible to minimize sublimation of the ice within the sample. One set of holes generated by the rasp can be seen in the middle upper portion of the Snow Trench in Figure 10.

Several attempts were made to acquire and deliver an icy-soil sample. On the first two attempts the sample appeared to congeal in the scoop during the delivery process most likely due to solar radiation impinging directly on the sample causing the sample to stick to the scoop during the dump. A third icy sample was acquired and successfully delivered by scraping material off the surface which yielded a sample with less ice, but one that did not congeal. Data

from the TEGA confirmed the presence of water ice in the sample, a key objective of the Phoenix mission. A fourth icy sample was acquired by rasping and carefully sequencing the scoop motions to minimize solar energy impingement and a delivery attempted to another TEGA cell, but the doors of the cell did not completely open causing the delivery to be unsuccessful.

Rock Push

Of particular interest to the science geomorphology group was investigating the conditions underneath surface rocks and their affect on the topography of the ice table. An experiment was devised where the arm excavated a trench below a rock and then pushed the rock into the trench revealing the surface underneath the rock. The push was done with the front of the scoop using a 0.5 m long guarded move (Figure 15).



Figure 15 — On sol 117 the RA pushed a rock 0.5 m into a trench excavated below it using the scoop to reveal the surface underneath

Trench Wall Failure Experiment

One of the materials properties experiments conducted was to intentionally cause a trench cave in. The experiment was done on sol 116 on the southwest side of the Dodo-Goldilocks trench by pressing down with the bottom of the scoop using a guarded move. Maximum vertical force of approximately 70 N caused slope failure, consistent with cohesive strengths and angles of internal friction found for cloddy soils at the Viking Lander 2 site. Pre- and post-images of the area shows the impression made by the scoop on the surface and as well as material fallen into the trench (Figure 16).

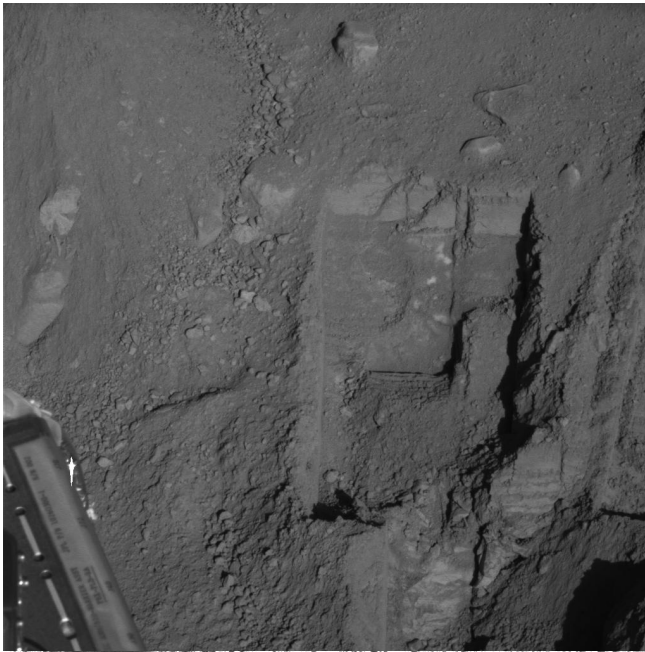

Figure 16 — The SSI captured the state of the Dodo-Goldilocks trench before and after the cave in experiment on sol 116 clearly showing the impression made by the scoop and material in the trench

Miscellaneous Activities

The RAC was a very useful tool in assessing the condition of the Lander and instruments. Prior to interaction of the RA with the terrain, Lander stability was assessed by imaging the three Lander footpads with the RAC. The back footpad could only be seen by looking underneath the Lander (Figure 17). This image along with those of the other two footpads verified that it was safe to proceed with digging.



Figure 17 — The RA positioned the RAC to take this image of the back footpad by looking underneath the Lander to support assessment of Lander stability

Imaging by the RAC of both the MECA and TEGA instrument ports pre- and post-sample delivery proved to be very useful in determining the readiness of the instruments to receive samples as well as the results of the sample delivery. This was particularly useful for the TEGA because of the problems with the doors of the TEGA ports not opening completely. Figure 18 shows the state of the south side TEGA ports after all samples were delivered. Similar images taken before delivery allowed the RA operators to adjust the arm motions for delivery to improve the chances of hitting the smaller targets.

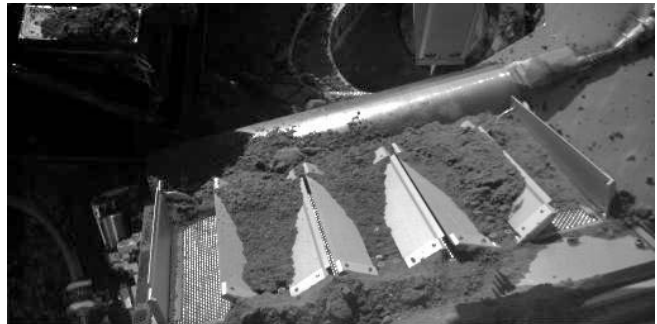

Figure 18 — This picture was taken by the RAC showing the south-side four ports of the TEGA after all samples had been successfully delivered to ports with partially opened doors

On sol 118 the RA carefully moved the RAC into position for the SSI and RAC to take mutual portraits of each. The RAC LEDs were turned on so that the RAC engineers could assess their performance (Figure 19).

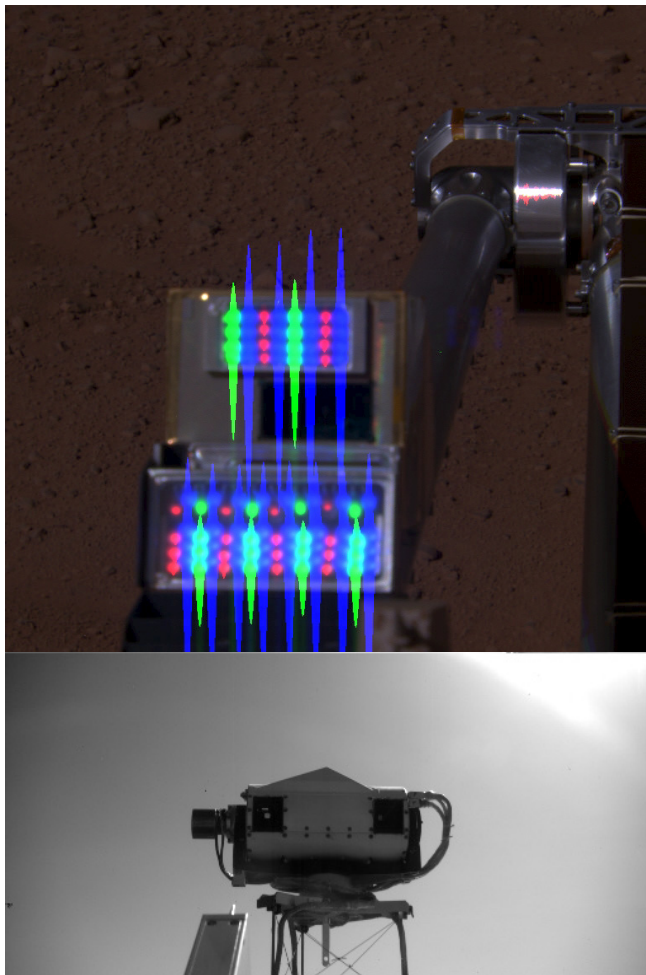

Figure 19 – The RA carefully positioned the RAC so that SSI and RAC could image each other on sol 116

4. CONCLUSION

This paper has described the salient features of the Phoenix Mars Lander Robotic Arm and its use in carrying out *in situ* operations in support of the science objectives of Phoenix mission. The ability to carry out high-level activities interacting with the terrain such as digging, scraping, and sample acquisition in a robust manner greatly contributed to the success of the Phoenix mission. As such, the Phoenix Robotic Arm has continued to advance NASA's capabilities in autonomous manipulation, sample acquisition, and *in situ* science investigations.

ACKNOWLEDGEMENTS

The research described in this paper was carried out by the Jet Propulsion Laboratory, California Institute of Technology, under a contract with the National Aeronautics and Space Administration. We would like to acknowledge the efforts of the following in the development of the Phoenix RA: Greg Pixler, Mike Newell, Veronica Lacayo, Kyle Brown, Greg Pomrehn, Suparna Mukherjee, Enrique Baez, Heidi Kelman, Don Noon, Jun Liu, Ryan Falor;

Kevin Burke, Alliance Spacesystems, Inc. (the RA subcontractor), Greg Peters for coming up with the rasp concept; and the Lockheed Martin team.

REFERENCES

- [1] Boynton, W., et al., Thermal and Evolved Gas Analyzer: Part of the Mars Volatile and Climate Surveyor integrated payload, *Journal of Geophysical Research*, 2001, 106(E8), 17683-17698
- [2] Kounaves, S., et al, The 2007 Phoenix Mars Scout Lander Microscopy, Electrochemistry, and Conductivity Analyzer Wet Chemistry Laboratory, *Journal of Geophysical Research*, 2008, doi:10.1029/2008JE003084
- [3] Hecht, M. H., Microscopy capabilities of the Microscopy, Electrochemistry, and Conductivity Analyzer, *Journal of Geophysical Research*, 2008, doi:10.1029/2008JE003077
- [4] Schenker, P. S., et al., Mars lander robotics and machine vision capabilities for in situ planetary science, in *Intelligent Robots and Computer Vision XIV*, SPIE Proc. 2588, 1995, Philadelphia, PA
- [5] NPR 8020.12B Planetary Protection Provisions for Robotic Extraterrestrial Missions, Rev. B, April 16, 1999
- [6] Cooper, B., Driving on the Surface of Mars Using the Rover Control Workstation, *Proc. Space Ops '98*, Tokyo, Japan
- [7] Bonitz, R. G., et al., The Mars Volatiles and Climate Surveyor Robotic Arm, *Journal of Geophysical Research - Planets*, 106(E8), August 2001, 623-640
- [8] Taylor, R., Planning and execution of straight-line manipulator trajectories, *IBM Journal of Research and Development*, 1979, 23(4), 424-436
- [9] Zent, A. P., et al, The Thermal Electrical Conductivity Probe (TECP) for Phoenix, *Journal of Geophysical Research*, 2008, doi:10.1029/2007JE003052
- [10] Smith, P. H., et al., Introduction to special section on the Phoenix Mission: Landing Site Characterization Experiments, Mission Overviews, and Expected Science, *Journal of Geophysical Research*, 2008, 113, E00A18, doi:10.1029/2008JE003083

- [11] Bonitz, R. G., et al., NASA Mars 2007 Phoenix Lander Robotic Arm and Icy Soil Acquisition Device, *Journal of Geophysical Research*, 2008 VOL. 113, E00A01, doi:10.1029/2007JE003030
- [12] Mellon, M. T., et al, Periglacial landforms at the Phoenix landing site and the northern plains of Mars, *Journal of Geophysical Research*, 2008, doi:10.1029/2007JE003039
- [13] Salinas, Y., et al, Bio-barriers: Preventing forward contamination and protecting planetary astrobiology instruments, *IEEE Aerospace Conference Proceedings, 2007 IEEE Aerospace Conference Digest, 2007*, p. 4161294

BIOGRAPHY



Robert G. Bonitz is principal engineer with the Mobility and Manipulation Group at the Jet Propulsion Laboratory. He was the Phoenix Lander 2007 Robotic Arm Manager. Previously he developed the control algorithms and software for the Mars Exploration Rover and Mars Polar Lander robotic arms. He has conducted research in control algorithms for multiple-manipulator robotic systems, robust internal force-based impedance controllers, frameworks for general force decomposition, optimal force control algorithms, and calibration methods for multi-arm robotic systems. He has worked for a variety of industrial companies including Raytheon, TRW, Source 2 International, and GTE. He has a Ph.D. in Electrical Engineering from the University of California, Davis.



Matthew L. Robinson was the Phoenix Lander Flight Software Lead for the Robotic Arm and served as a member of the operations team. His on-going research efforts have included the development of calibration-free, stereo-based manipulation techniques (HIPS) and general control systems for holonomic and hybrid nonholonomic/holonomic systems. Other research interests include machine vision, manipulation, mechatronic systems and controls. He is a member of the engineering staff in the Mobility and Manipulation Group at the Jet Propulsion Laboratory, where he has been since 2001.



Joseph Carsten graduated from Carnegie Mellon University in 2005 with a M.S. in Robotics. Since then he has been a member of the JPL technical staff and was a member of the Phoenix Robotic Arm operations team.



Richard Volpe is Manager of the Mobility and Robotic Systems Section (347) of the Autonomous Systems Division. The section is a team of over 80 robotics engineers doing research and spaceflight implementation of robotic systems for Roving, Digging, Ballooning, Drilling, and other modes of in-situ planetary exploration. He served on the Phoenix Robotic Arm operations team. Additionally, Richard is a member of JPL's Science and Technology Management Committee (STMC). From 2001 through 2004, Richard served as the manager of Mars Regional Mobility and Subsurface Access in JPL's Space Exploration Technology Program Office. In addition to guiding technology development for future robotic exploration of Mars and the Moon, he has been actively involved in 2003 & 2009 rover mission development, and 2007 lander mission operations. This has included managing internal JPL rover technology development, as well as external university research funded by the Mars Technology Program.



Dr. Ashitey Trebi-Ollennu is a Senior Member of Engineering Staff at the NASA-Jet Propulsion Laboratory, California Institute of Technology, in Pasadena, CA and a Fellow of the IEE (U.K.). His current research at JPL focuses on Planetary Rovers, Manipulation, Multiple Mobile Robots (Planetary Outpost), Reconfigurable Robots and Man-machine Interaction. Dr. Trebi-Ollennu's research has resulted in more than 65 publications. He worked on the Mars Exploration Rover Operations Team as a Rover Planner (Rover Driver) responsible for Surface Mobility/Navigation Planning, IDD Planning, and Command Generation. He served as a member of the Phoenix Robotic Arm operations team.

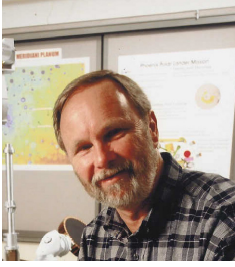

Raymond E. Arvidson, James S. McDonnell Distinguished University Professor at Washington University in Saint Louis. Robotic Arm Co-Investigator for the Phoenix Team, Deputy Principal Investigator for the Mars Exploration Rover Missions (Spirit and Opportunity), Co-Investigator

for the CRISM Hyperspectral Imaging Experiment on the Mars Reconnaissance Orbiter and the OMEGA hyperspectral imaging experiment on the European Space Agency's Mars Express Orbiter. Arvidson is currently the Director of the NASA Geosciences Node of the Planetary Data System. He was the Team Leader for the Viking Lander Imaging Experiment for the extended missions. Arvidson was the 2007 recipient of the Whipple Award of the American Geophysical Union and was elected as an American Geophysical Union Fellow in 2006. He is a planetary geologist whose interests focus on surface processes on Earth, Mars, and Venus.